

Online UPS

PowerWalker VFI 10000TCP 3/1

PowerWalker VFI 10000TP 3/1

PowerWalker VFI 20000TP 3/1



Manual
EN

Uninterruptible Power Supply System

CONTENT:

1. Safety	1
1.1 Installation.....	1
1.2 Operation	2
1.3 Maintenance, Servicing and Faults	3
1.4 Transport	4
1.5 Storage	4
1.6 Standards	5
2. Description of Commonly Used Symbols	6
3. Introduction	7
3.1 System and Model Description.....	7
3.2 Product Specification and Performance	10
4. Installation	13
4.1 Unpacking and Inspection	13
4.2 Input and Output Power Cords and Protective Earth Ground Installation.....	16
4.3 Operating Procedure for Connecting with The External Battery	21
5. Operation	23
5.1 Display Panel.....	23
5.2 Operating Mode.....	27
5.3 Turning On and Turning Off UPS	29
5.4 LCD Operation.....	31
6. Special function	40
6.1 HE Function	40

6.2 Converter Function	40
6.3 Parallel Function.....	41
6.4 PowerWalker VFI 10000TCP 3/1 Optional Design of Charger Current	47
6.5 Backfeed Protection	48
7. Trouble Shooting	51
7.1 Trouble Shooting According To Warning Indication.....	51
7.2 Trouble Shooting According To Fault Indication	53
7.3 Trouble Shooting In Else Cases	54
8. Battery Maintenance, Replacement and Disposal	56
8.1 Maintenance	56
8.2 Replacement and Disposal of Batteries	57
9. Communication Port.....	60
9.1 RS232&USB Interface.....	60
9.2 Intelligent Slot	60
9.3 AS400 Interface (Option)	60
10. Software Installation.....	Error! Bookmark not defined.

1. Safety

Please read carefully the following user manual and the safety instructions before installing the unit or using the unit!

1.1 Installation

- ★ Condensation may occur if the UPS is moved directly from a cold to a warm environment. The UPS must be absolutely dry before being installed. Please allow an acclimatization time of at least two hours.
- ★ Do not install the UPS near water or in damp environment.
- ★ Do not install the UPS where it would be exposed to direct sunlight or near heat.
- ★ Do not block ventilation openings in the UPS's housing.
- ★ Do not connect appliances or items of equipment which would overload the UPS (e.g. laser printers, etc) to the UPS output.
- ★ Place cables in such a way that no one can step on or trip over them.
- ★ UPS has provided earthed terminal, in the final installed system configuration, equipotential earth bonding to the external UPS battery cabinets.
- ★ An integral single emergency switching device which prevents further supply to the load by the UPS in any mode of operation should be provided in the building wiring installation.

- ★ An appropriate disconnect device as short-circuit backup protection should be provided in the building wiring installation.
- ★ For three-phase equipment connection to an IT power system, a four-pole device which disconnect all phase conductors and the neutral conductor should be provided in the building wiring installation.
- ★ This is permanently connected equipment, it must be installed by qualified maintenance personnel.
- ★ Earth connection essential before connecting to the building wiring terminal.

1.2 Operation

- ★ Do not disconnect the earth conductor cable on the UPS or the building wiring terminals in any time since this would cancel the protective earthing of the UPS system and of all connected loads.
- ★ The UPS output terminal block may be electrically lived even if the UPS system is not connected to the building wiring terminal.
- ★ In order to fully disconnect the UPS, turn the M1/M2/N input breaker in the "OFF" position (for PowerWalker VFI 10000-20000 TP 3/1), turn the R/S/T/N input switch in the "OFF" position (for PowerWalker VFI 10000TCP 3/1), then disconnect the mains lead.

- ★ Ensure that no liquid or other foreign objects can enter the UPS.

1.3 Maintenance, servicing and faults

- ★ The UPS operates with hazardous voltages. Repairs should be carried out only by qualified maintenance personnel.
- ★ Caution - risk of electric shock. Even after the unit is disconnected from the mains power supply (building wiring terminal), components inside the UPS are still connected to the battery which are potentially dangerous.
- ★ Before carrying out any kind of service and/or maintenance, please disconnect the batteries. Verify that no current is present and no hazardous voltage exists in the capacitor or BUS capacitor terminals.
- ★ Batteries must be replaced only by qualified personnel.
- ★ Caution - risk of electric shock. The battery circuit is not isolated from the input voltage. Hazardous voltages may occur between the battery terminals and the ground. Verify that no voltage is present before servicing!
- ★ Batteries have a high short-circuit current and pose a risk of shock. Take all precautionary measures specified below and any other measures necessary when working with batteries:
 - remove all jewellery, wristwatches, rings and other metal objects

- use only tools with insulated grips and handles.

- ★ When changing batteries, replace with the same quantity and the same type of batteries.

- ★ Do not attempt to dispose of batteries by burning them. It could cause explosion.

- ★ Do not open or destroy batteries. Effluent electrolyte can cause injury to the skin and eyes. It may be toxic.

- ★ Please replace the fuse only by a fuse of the same type and of the same amperage in order to avoid fire hazards.

- ★ Do not dismantle the UPS, except the qualified maintenance personnel.

1.4 Transport

- ★ Please transport the UPS only in the original packaging (to protect against shock and impact).

1.5 Storage











- ★ The UPS must be stockpiled in the room where it is ventilated and dry.

1.6 Standards

* Safety	
IEC/EN 62040-1	
* EMI	
Conducted Emission.....:IEC/EN 62040-2	Category C3
Radiated Emission.....:IEC/EN 62040-2	Category C3
* EMS	
ESD.....:IEC/EN 61000-4-2	Level 3
RS.....:IEC/EN 61000-4-3	Level 3
EFT.....:IEC/EN 61000-4-4	Level 4
SURGE.....:IEC/EN 61000-4-5	Level 4
Low Frequency Signals.....:IEC/EN 61000-2-2	
Warning: This is a product for commercial and industrial application in the second environment-installation restrictions or additional measures may be needed to prevent disturbances.	

2. Description of Commonly Used Symbols

Some or all of the following symbols may be used in this manual. It is advisable to familiarize yourself with them and understand their meaning:

Symbol and Explanation			
Symbol	Explanation	Symbol	Explanation
	Alert you to pay special attention		Alternating current source (AC)
	Caution of high voltage		Direct current source (DC)
	Turn on the UPS		Protective ground
	Turn off the UPS		Recycle
	Idle or shut down the UPS		Do not dispose with ordinary trash

3. Introduction

3.1 System and model description

This Online Series is an uninterruptible power supply incorporating double-conversion technology. It provides perfect protection specifically for computer equipment, communication systems to computerized instruments.

Its true online double-conversion design eliminates all mains power disturbances. A rectifier converts the alternating current from the utility power to direct current. This direct current powers the inverter. On the basis of this DC voltage, the inverter generates a pure sinusoidal AC voltage, which is constantly powering the loads.

Computers and Peripherals are thus powered entirely by the UPS. In the event of power failure, the maintenance-free batteries power the inverter.

This manual is applicable to the PowerWalker VFI 10000-20000 TP 3/1 models and PowerWalker VFI 10000TCP 3/1 model.

The tower 3-phase series UPS providing outstanding performance and reliability, the UPS's unique benefits include:

- Online UPS design with pure sine wave output.
- True online double-conversion technology with high power density, utility frequency independence, and generator compatibility.
- Overall high efficiency > 93%, saving the operating cost.
- True three-phase power factor correction and high input power factor (PF>0.99). Save the installation cost and reduce the pollution back feed into upstream power system.

- High output power factor (0.9), to adapt more type load.
- Intelligent Battery Management technology that uses advanced battery management to increase battery service life, optimize recharge time.
- Selectable High Efficiency mode (ECO mode) or CVCF mode operation.
- Combo input (single phase or three phase) auto detection
- Back-feed protection
- Start-on-battery capability for powering up the UPS even if utility power is not available.
- Standard communication options: one RS-232 communication port, one USB communication port.
- Optional connectivity cards with enhanced communication capabilities.
- Remote shutdown control through the Remote Power-off (RPO) port.
- For tower PowerWalker VFI 10000-20000 TP 3/1, Maintenances are simplified by allowing the safe replacement of batteries without powering down the UPS. But PowerWalker VFI 10000TCP 3/1 model have no this function.
- N+X parallel redundancy to increase the reliability and flexibility. The max parallel number is 4.
- User-friendly LCD display and LED indicators.
- For tower PowerWalker VFI 10000-20000 TP 3/1, easily battery exchange or extension and available to extend the backup time. But PowerWalker VFI 10000TCP 3/1 model have no this function.

The appearance of tower 3-phase series

Refers to Fig. 3-1

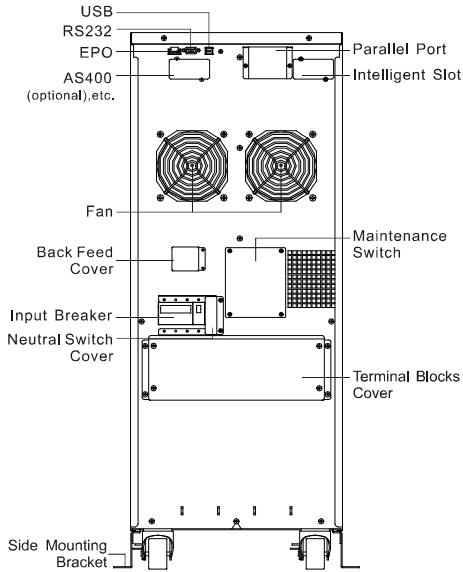

PowerWalker VFI 10000 TP 3/1 REAR VIEW

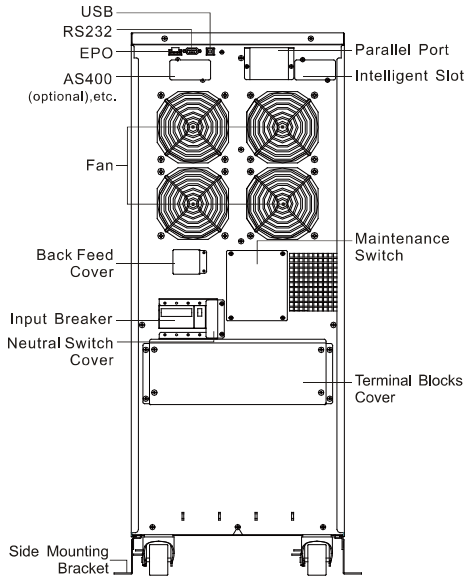

PowerWalker VFI 20000 TP 3/1 REAR VIEW

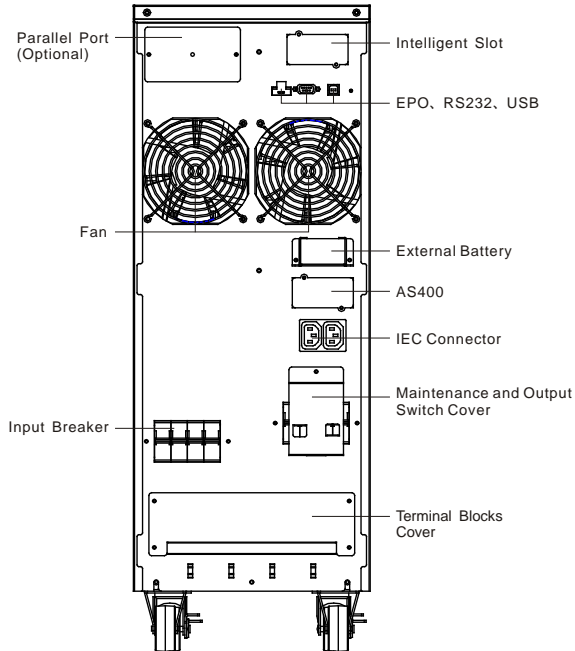

PowerWalker VFI 10000TCP 3/1 REAR VIEW

Fig. 3-1 the rear view of the tower 3-phase series UPS

3.2 Product Specification and Performance

1) General Specification

Model		PowerWalker VFI 10000TP 3/1	PowerWalker VFI 20000TP 3/1	PowerWalker VFI 10000TCP 3/1
Power Rating		10KVA/9KW	20KVA/18KW	10KVA/9KW
Frequency (Hz)		50/60		
Input	Voltage	(110-276)VAC (Depends on Load Level)		
	Current	L1/L2/L3 : 23A MAX	L1/L2/L3 : 46A MAX	L1/L2/L3 : 23A MAX
Battery	Voltage	288VDC		240VDC

	Current	43A MAX	86A MAX	51.8A MAX
Output	Voltage	200VAC/208VAC/220VAC/230VAC/ 240VAC*		
	Current	45A/48.1A/45.5A/4 3.5A/41.7A	90A/96.2A/90.9A/8 7.0A/83.3A	45A/48.1A/45.5A/4 3.5A/41.7A
Dimension (WxDxH) mm		350x650x890		260*550*708
Net Weight (kg)		127	188	85

2) Electrical Performance

Input			
Model	Voltage	Frequency	Power Factor
PowerWalker VFI 10000TP 3/1 PowerWalker VFI 20000TP 3/1 PowerWalker VFI 10000TCP 3/1	Three-phase	50/60 Hz±10%	>0.99(@Full load)

*: If output voltage be set 200V, output power will derating to 90% of power rating

Output					
Voltage Regulation	Power Factor	Frequency tolerance.	Distortion	Overload capacity	Current crest ratio
±1%	0.9 lag	Synchronized 50/60Hz±10% in Line mode (AC mode) ±0.1% of normal frequency in Battery mode	THD<2% Full load (Linear Load)/ <5% for reference non-linear load	100%-110% load transfers to Bypass mode after 5 minutes 110%-130% load transfers to Bypass mode after 1 minutes 130%-150% load transfers to Bypass mode after 10 second >150% load transfers to Bypass mode after 2 second	3:1

3) Operating Environment

Temperature	Humidity	Altitude	Storage temperature
0°C-45°C	<95%	<1000m	-15°C-50°C

Note: if the UPS is installed or used in a place where the altitude is above than **1000m**, the output power must be derated in use, please refer to the following:

Altitude (M)	1000	1500	2000	2500	3000	3500	4000	4500	5000
Maximum Power	100%	95%	91%	86%	82%	78%	74%	70%	67%

4. Installation

The system may be installed and wired only by qualified electricians in accordance with applicable safety regulations!

4.1 Unpacking and Inspection

1. Moving to the installation site



The tower 3-phase series UPS has wheels making it easy to move the UPS to the installation site after it has been unpacked. However, if the receiving area is far from the installation site, we recommend you to move the UPS by using a pallet jack or a lifter before you start to unpack the UPS.

2. Unpacking and inspection

1) At the installation site, the utmost care shall be taken when removing the packaging in order to avoid damaging the equipment. Check all packaging materials to ensure that no items are missing. The shipping package contains:

- A UPS
- A user manual
- A communication cable
- Parallel port cover plate

Remove the packaging following the sequence illustrated in Fig. 4-1 to Fig. 4-4. (only for PowerWalker VFI 10000-20000 TP 3/1)

Tools kit			
	Lifter		Phillips screwdriver
	Scissors		Wrench

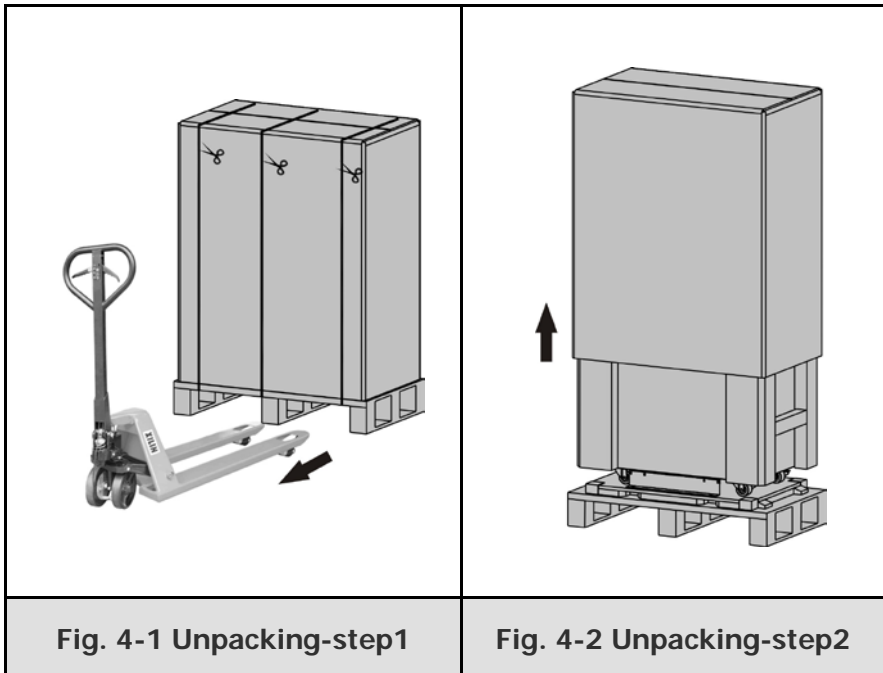

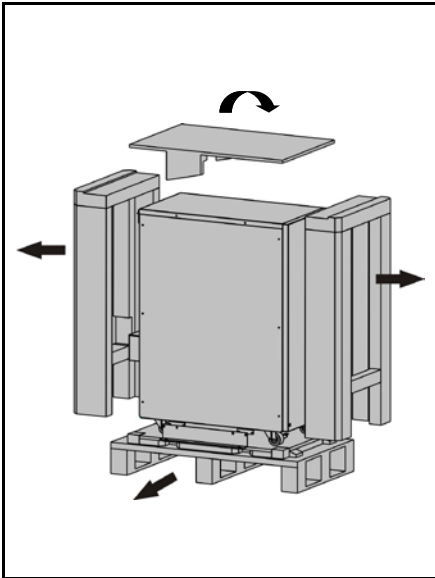

Fig. 4-3 Unpacking-step3

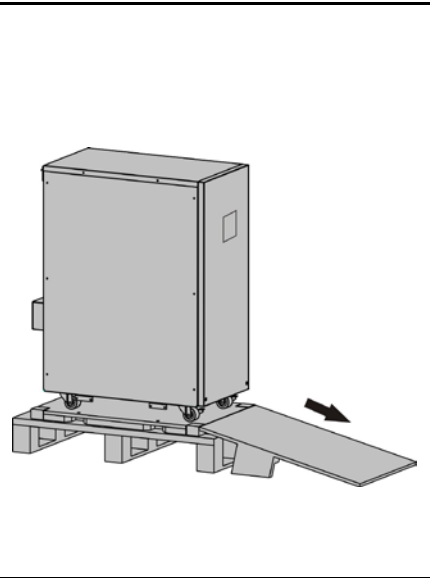

Fig. 4-4 Unpacking-step4



The shipping materials are recyclable. After unpacking, save them for later use or dispose of them appropriately.

- 2) Inspect the appearance of the UPS to see if there is any damage during transportation. Do not turn on the unit and notify the carrier and dealer immediately if there is any damage or lacking of some parts.

4.2 Input and Output Power Cords and Protective Earth Ground Installation

1. Notes for installation

- 1) The UPS must be installed in a location with good ventilation, far away from water, inflammable gas and corrosive agents.
- 2) Ensure the air vents on the front and rear of the UPS are not blocked. Allow at least 0.5m of space on each side.
- 3) Condensation to water drops may occur if the UPS is unpacked in a very low temperature environment. In this case it is necessary to wait until the UPS is fully dried inside out before proceeding installation and use. Otherwise there are hazards of electric shock.
- 4) Once the installation is completed, the side mounting brackets (used in shipping) shall be fixed back to ensure the stability of the UPS enclosure. If impossible, additional stability can be added by anchoring the mounting brackets to the floor with M8 bolts. See Fig. 4-5. (only for PowerWalker VFI 10000-20000 TP 3/1)

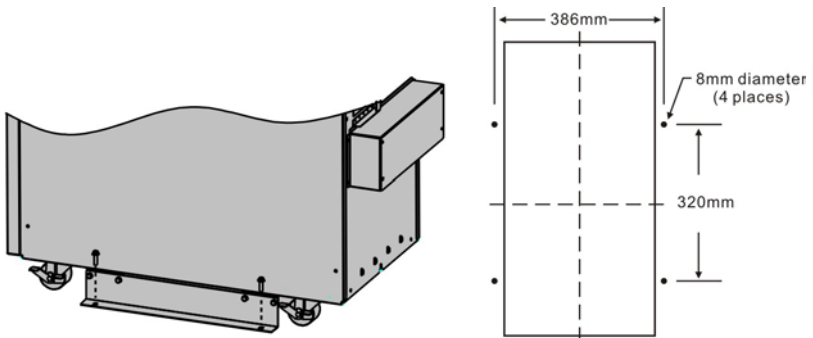

Fig. 4-5 Additional stability

2. Installation

Installation and wiring must be performed in accordance with the local electric code and the following instructions by professional personnel.

For safety, please cut off the mains power switch before installation.

- 1) Open the terminal block cover located on the rear panel of the UPS, please refer to the appearance diagram.
- 2) For tower PowerWalker VFI 10000TCP 3/1 UPS, it is recommended to select the UL1015 8AWG(10mm²) wire or other insulated wire which complies with AWG Standard for the UPS input and output wirings.
- 3) For PowerWalker VFI 20000TP 3/1 UPS, it is recommended to select the UL1015 6AWG(25mm²) wire or other insulated wire which complies with AWG Standard for the UPS input and output wirings.

Note: Do not use the wall receptacle as the input power source for the UPS, as its rated current is less than the UPS's maximum input current. Otherwise the receptacle may be burned and destroyed.

- 4) Connect the input and output wires to the corresponding input and output terminals according to the following diagram.

Note: you must make sure that the input and output wires and the input and output terminals are connected tightly.

- 5) The protective earth ground wire refers to the wire connection between the equipment which consumes electric equipment and the ground wire. The wire diameter of protective earth ground wire should be at least as above mentioned for each model and green wire or green wire with yellow ribbon wire is used.
- 6) After having completed the installation, make sure the wiring is correct.
- 7) Please install the output breaker between the output terminal and the load, and the breaker should with leakage current protective function if necessary.

- 8) To connect the load with the UPS, please turn off all the loads first, then perform the connection and finally turn on the loads one by one.
- 9) No matter the UPS is connected to the utility power or not, the output of the UPS may have electricity. The parts inside the unit may still have hazardous voltage after turning off the UPS. To make the UPS have no output, power off the UPS, and then disconnect the utility power supply.
- 10) Suggest charging the batteries for 8 hours before use. After connection, turn the M1/M2/N input breaker (for PowerWalker VFI 10000-20000TP 3/1), turn the input switch (for PowerWalker VFI 10000TCP 3/1) in the "ON" position, the UPS will charge the batteries automatically. You can also use the UPS immediately without charging the batteries first, but the backup time may be less than the standard value.
- 11) If it is necessary to connect the inductance load such as a monitor or a laser printer to the UPS, the start-up power should be used for calculating the capacity of the UPS, as its start-up power consumption is too big when it is started.

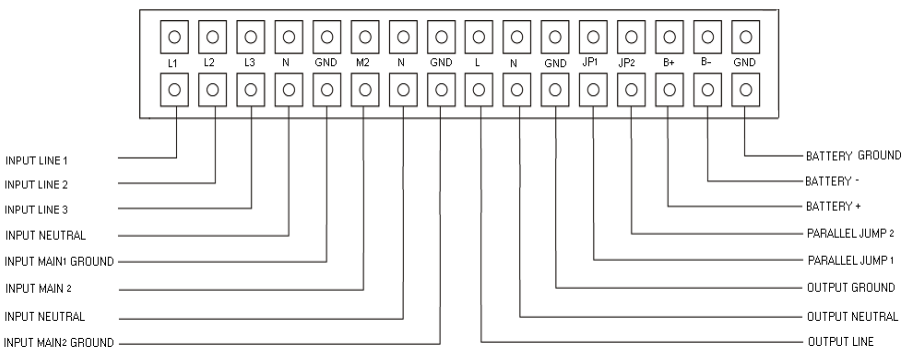

PowerWalker VFI 10000-20000TP 3/1

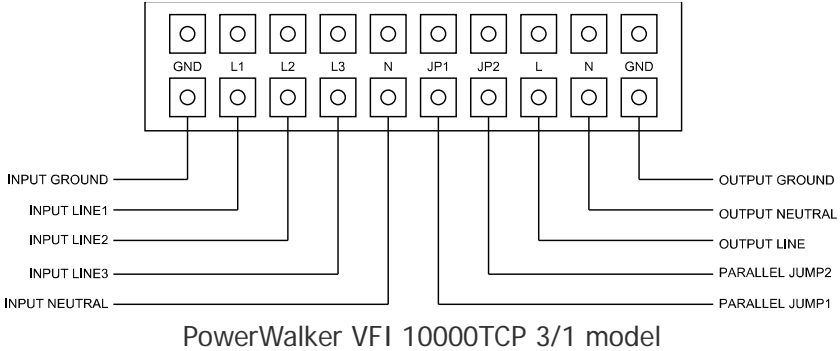

Fig. 4-6 Input and output Terminal Block wiring diagram

Important notes: If the UPS is used in single mode, JP1 and JP2 must be connected. If the UPS is used in parallel mode, the Jumper between JP1 and JP2 must be removed.

Use cable cross section and protective device specification

Model	PowerWalker VFI 10000TP 3/1	PowerWalker VFI 20000TP 3/1
Input L1,L2,L3		
Min.conductor cross section[mm ²]	2.5	6
Max.conductor cross section[mm ²]	4	10
Input L1,L2,L3 breaker (A)	40A,250VAC	60A,250VAC
Input N, M2		
Min.conductor cross section[mm ²]	10	21
Max.conductor cross section[mm ²]	13	25
Input M2 breaker (A)	63A,250VAC	100A,250VAC
Input fuse (A)	30A,250VAC	50A,690AC
Output L,N,		
Min.conductor cross section[mm ²]	10	21
Max.conductor cross section[mm ²]	13	25

External Battery Cabinet Positive Pole(+),Neutral pole,Negative pole(-),		
Min.conductor cross section[mm²]	10	21
Max.conductor cross section[mm²]	13	25
Line input Backfeed protection device	A 4-pole disconnection device with 100A/250VAC, less than 15s break time and min. 1.4mm clearance will be used in final installation for backfeed protection in line input.	
M2 input Backfeed protection device	A 2-pole disconnection device with 100A/250VAC, less than 15s break time and min. 1.4mm clearance will be used in final installation for backfeed protection in line input.	
Protective Earthing conductor[mm²]	Max.13	Max.25
Torque for fixing above terminals	(10 1b in)	(18 1b in)

Sheet.1 PowerWalker VFI 10000-20000TP 3/1 models

Model	PowerWalker VFI 10000TCP 3/1
Input L2,L3	
Min.conductor cross section[mm²]	2.5
Max.conductor cross section[mm²]	4
Input L1,L2,L3,N switch (A)	63A,250VAC
Output switch(A)/maintain switch(A)	63A,250VAC
Input L1,N	
Min.conductor cross section[mm²]	10
Max.conductor cross section[mm²]	13
Input fuse (A)	30A,250VAC
Output L,N,	

Min.conductor cross section[mm ²]	10
Max.conductor cross section[mm ²]	13
External Battery Cabinet Positive Pole(+),Neutral pole,Negative pole(-),	
Min.conductor cross section[mm ²]	10
Max.conductor cross section[mm ²]	13
Protective Earthing conductor[mm ²]	MAX 13
Torque for fixing above terminals	(10 lb in)

Sheet.2 PowerWalker VFI 10000TCP 3/1 model

4.3 Operating Procedure for Connecting with The External Battery

1. For PowerWalker VFI 10000-20000TP 3/1, The nominal DC voltage of external battery pack is 288VDC. Each battery pack consists of 24 pieces of 12V maintenance free batteries in series. For PowerWalker VFI 10000TCP 3/1 model, the nominal DC voltage of external battery pack is 240VDC. Each battery pack consists of 20 pieces of 12V maintenance free batteries in series ,To achieve longer backup time, it is possible to connect multi-battery packs, but the principle of “same voltage, same type” should be strictly followed.
2. For PowerWalker VFI 10000-20000TP 3/1, select the UL1015 8AWG (10mm²)/6AWG (25mm²) wire respectively or other insulated wire which complies with AWG Standard for the UPS battery wirings. The procedure of installing battery bank should be complied with strictly. Otherwise you may encounter the hazardous of electric shock.
 - 1) For tower 3/1 series if the UPS has internal battery pack, first of all, disconnect the internal battery pack DC connectors.

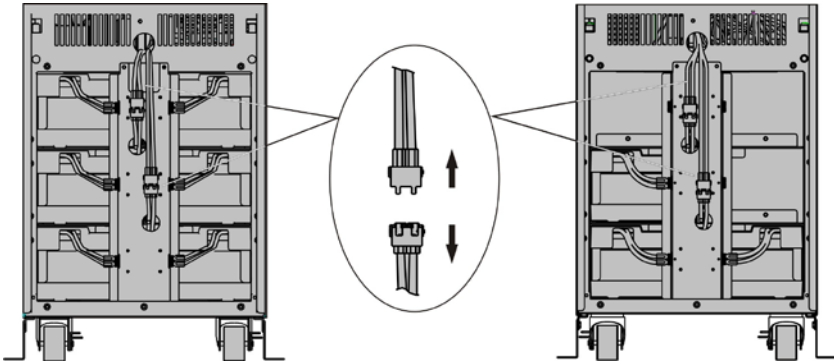

PowerWalker VFI 20000TP 3/1

PowerWalker VFI 10000TP 3/1

Fig. 4-7 Disconnect the internal battery pack DC connectors

- 2) A DC breaker must be connected between the external battery pack and the UPS. The capacity of breaker must be not less than the data specified in the general specification.
 - 3) Set the external battery pack breaker in "OFF" position and connect the batteries (24 pieces for PowerWalker VFI 10000-20000TP 3/1, 20 pieces for PowerWalker VFI 10000TCP 3/1) in series.
 - 4) For PowerWalker VFI 10000-20000TP 3/1, Connect the external battery pack to the battery terminals. For PowerWalker VFI 10000TCP 3/1 model, Connect the external battery pack to the battery anderson connector.
 - 5) Reconnect the internal battery pack DC connectors, if you had did step one.
3. Do not attempt to connect any loads to the UPS now. You should connect the input power wire to the right position first. And then set the breaker of the battery pack in the "ON" position. After that set the input breaker in the "ON" position. The UPS begins to charge the battery packs at the time.

5. Operation

5.1 Display Panel

The UPS has a four-button graphical LCD with dual color backlight. Standard back-light is used to light up the display with white text and a blue background. When the UPS has a critical alarm, the backlight changes the text to dark amber and the background to red. Besides the graphical LCD, the UPS has four colorized LEDs to provide you more convenient info.

See Figure Below

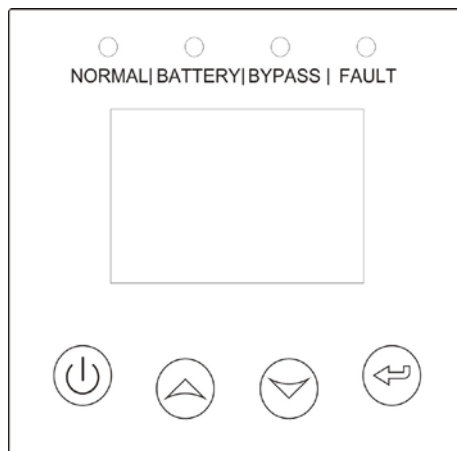

Fig. 5-1 PowerWalker VFI 10000-20000TP 3/1/ PowerWalker VFI 10000TCP 3/1 UPS Control Panel

Table 5-1 Control Button Functions





The Button	Function	Illustration
	Power on	When the unit is no power and has connected with battery, press this button for >100ms&<1s to power on
	Turn on	When the unit is powered on and in Bypass mode, press this button for >1s to turn on
	Turn off	When the unit has been turned on, press this button for >3s to turn off
	Enter main menu	When displaying default UPS status summary screen, press this button for >1s to enter the main menu tree
	Exit main menu	Press this button for >1s to exit the present menu to default system status display menu without executing a command or changing a setting
	Scroll up	Press this button for >100ms&<1s to scroll up the menu option
	Scroll down	Press this button for >100ms&<1s to scroll down the menu option
	Enter next menu tree	Press this button for >100ms&<1s to select the present menu option, or enter next menu, but do not change any setting
	Select one menu option	Press this button for >100ms&<1s to select the present menu option, or enter next menu, but do not change any setting
	Confirm the present setting	Press this button for >1s to confirm the edited options and change the setting

Table 5-2 LED definition

UPS state	Normal LED (Green)	Battery LED (Yellow)	Bypass LED (Yellow)	Fault LED (Red)
Bypass mode with no output			★	↑
Bypass mode with output			●	↑
Turning on	△	△	△	△
Line mode	●			↑
Battery mode	●	●		↑
HE mode	●		●	↑
Battery test mode	△	△	△	△
Fault mode			↑	●
Warning	↑	↑	↑	★

Note :

- : Lightened constantly
- △: # 1-#4 Lightened circularly
- ★: Flashing
- ↑: Depended on the fault/warning status or other status

Table 5-3 Buzzer definition

UPS condition	Buzzer status
Fault active	Continuous
Warning active	Beep every second
Battery output	Beep every 4 seconds, if battery low, buzzer Beep every second
Bypass output	Beep every 2 minutes

The UPS provides useful information about UPS itself, load status, events, measurements, identification, and settings through the front panel display.

After powering on, the LCD will display the “WELCOME” logo for several seconds and then enter to the default page which shows the UPS status summary. The display automatically returns to the default UPS status summary screen when no button has been pressed within 15 minutes.

On the UPS status summary screen it provides the following information:

- Status summary, including mode and load
- Alarm status, if any are present
 - Notes: alarm including fault and warning information
- Battery and charger status, including battery voltage, charger level and charger status
- Running information including parallel UPS and running time

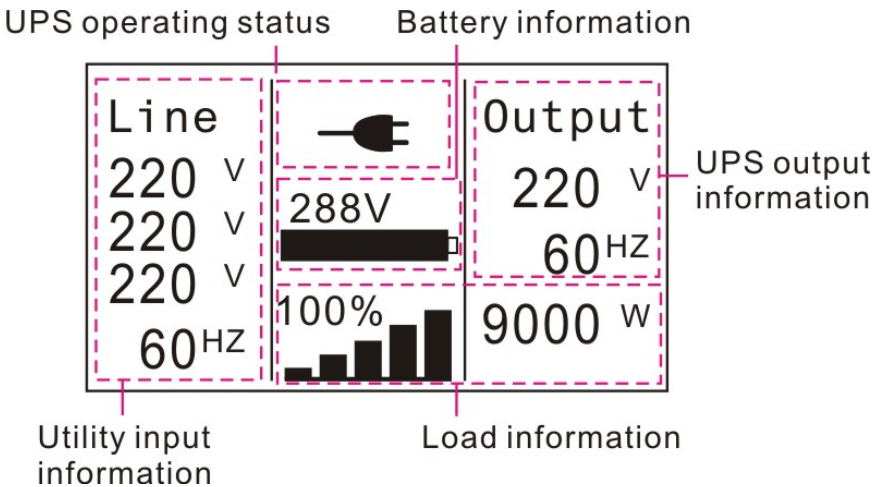

Fig. 5-2 The default LCD display

The more detailed operation of LCD is illustrated in the chapter of 5.4.

5.2 Operating Mode

The different graphic symbol could be displayed corresponding to current operating mode or status.

Table 5-4 Status Summary Screens

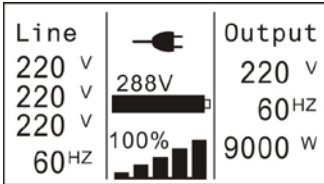
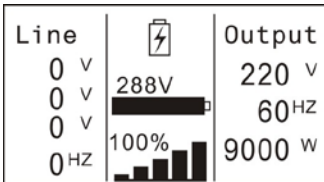
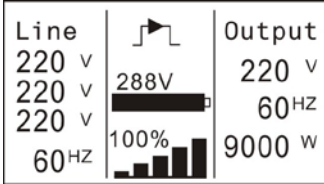
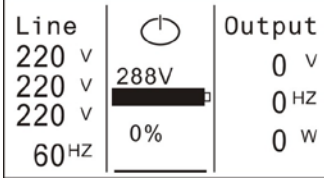
Status Summary Screen	Description
 <p style="text-align: center;">Fig 5-3</p>	<p>Normal mode:</p> <p>The UPS is operating in Normal mode from utility power.</p>
 <p style="text-align: center;">Fig 5-4</p>	<p>Battery mode:</p> <p>When the UPS is running in battery mode, the buzzer beeps once every 4 seconds.</p>
 <p style="text-align: center;">Fig 5-5</p>	<p>Bypass with output:</p> <p>The UPS does not have the backup function when it is in bypass mode. The power used by the load is supplied from the utility power via internal filter. The UPS will beep once every 2 minutes in bypass mode.</p>
 <p style="text-align: center;">Fig 5-6</p>	<p>Bypass without output:</p> <p>The UPS in bypass mode without output</p>

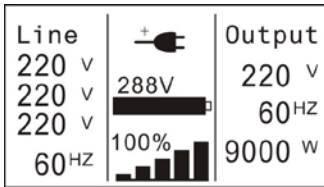

Fig 5-7

High Efficiency Mode:

After the UPS is turned on, the power used by the load is supplied from the utility power via internal filter while the utility power is in normal range, so the high efficiency could be gained in the HE mode. Once the mains is loss or abnormal, the UPS would transfer to Line mode or Battery mode and the load is supplied continuously.

- 1) The function could be enabled through the LCD setting or the software (Winpower, etc.).
- 2) It is attention that the transfer time of UPS output from HE mode to battery mode is about 10ms. But it is still too long for some sensitive load.

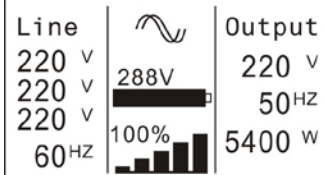

Fig 5-8

Converter mode

In converter mode, the UPS would free run with fixed output frequency (50Hz or 60Hz). Once the mains is loss or abnormal, the UPS would transfer to battery mode and the load is supplied continuously.

- 1) The function could be enabled through the LCD setting or the software (Winpower, etc.).
- 2) The load should be derated to 60% when running in converter mode with single phase input, and there is no derating with three phases input.

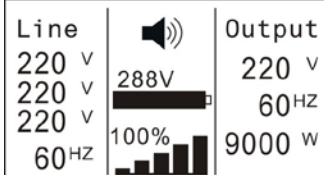
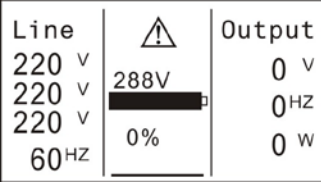
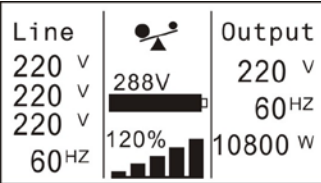
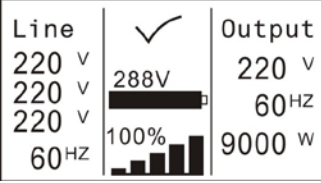
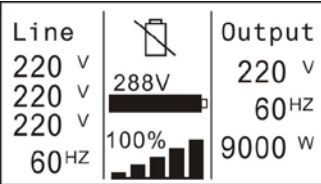

Fig 5-9

Warning:

When the warning occurs, it illustrates that there are some abnormal problems during the operation of UPS. Normally the problems are not fatal and the UPS continues working, but they should be paid attention to, or the UPS may fail.

 <p>Fig 5-10</p>	<p>Fault:</p> <p>When the fault occurs, it illustrates that some fatal problems happened, the UPS would directly cut off the output or transfer to bypass, and keep alarming. The backlight of LCD would also turn to red.</p>
 <p>Fig 5-11</p>	<p>Overload:</p> <p>When the UPS is overload, the alarm will beep twice every second. Some unnecessary loads should be get rid of one by one to decrease the loads connected to the UPS.</p>
 <p>Fig 5-12</p>	<p>Battery Test</p> <p>UPS is executing a battery test</p>
 <p>Fig 5-13</p>	<p>Battery fail:</p> <p>if the battery status detected is "bad battery detected" or "battery disconnected", the symbol of battery failure would be shown and UPS would alarm.</p>



5.3 Turning On and Turning Off UPS

Attention: Please switch off the connected loads first before turning on the UPS, and switch on the loads one by one after the UPS is turned on. Switch off all of the connected loads before turning off the UPS.

5.3.1 Turning On UPS With Utility

- 1) Check that power supply connection is correct. Check the breaker of battery pack is in "ON" position (this step only for long backup time model).
- 2) For PowerWalker VFI 10000-20000TP 3/1 set input breaker (M1 & M2) in "ON" position, for PowerWalker VFI 10000TCP 3/1 model set input 4P-switch in "ON" position .At this time the fan begins to rotate. LCD will show "WELCOME" logo. Then LCD will show the system status summary screen after UPS finishing self-test.
- 3) By pressing  button continuously for more than 1 second, the buzzer will beep 1s, UPS starts to turn on.
- 4) A few seconds later, the UPS turns into Line mode. If the utility power is abnormal, the UPS will transfer to Battery mode without output interruption of the UPS.

5.3.2 Turning On UPS Without Utility

- 1) Check the breaker of the battery pack is in "ON" position (this step only for long backup time model).
- 2) By pressing  button continuously for more than 100ms, the UPS would be powered on. At this time the fan begins to rotate, LCD will show the "WELCOME" logo. Then LCD will show the default UPS status summary screen after UPS finishing self-test.
- 3) By pressing  button continuously for more than 1 second, the buzzer will beep 1s, UPS starts to turn on.
- 4) A few seconds later, the UPS turns into Battery mode. If the utility power comes back, the UPS will transfer to Line mode without output interruption of the UPS.

5.3.3 Turning Off UPS With Utility

- 1) To turn off the inverter of UPS by pressing  button continuously for more than 3 seconds and the buzzer will beep 3s. The UPS will turn into Bypass mode at once.

- 2) When completing the above action, UPS output voltage is still present. In order to cut off the UPS output, simply cut off the utility power supply. A few seconds later, LCD display shuts down and no output voltage is available from the UPS output terminal.



5.3.4 Turning Off UPS Without Utility

- 1) To power off the UPS by pressing  button continuously for more than 3 second, and the buzzer will beep 3s. The UPS will cut off the output at once.
- 2) A few seconds later, LCD shuts down and no voltage is available from the UPS output.

5.4 LCD Operation

Except the default UPS status summary screen, the user could get more useful information about UPS current status, detailed various measurements, old events which ever occurred, UPS own identification, and could change the settings to fit the user own requirements, optimize the function of UPS.

5.4.1 The Main Menu

In the default UPS status summary screen, when pressing  or  <1s, the detailed information about alarm, the system status, battery would be shown.

In the default UPS status summary screen, when pressing  >1s, the display would enter main menu tree.

The main menu tree includes six branches: UPS status menu, event log menu, measurement menu, control menu, identification menu, setting menu.

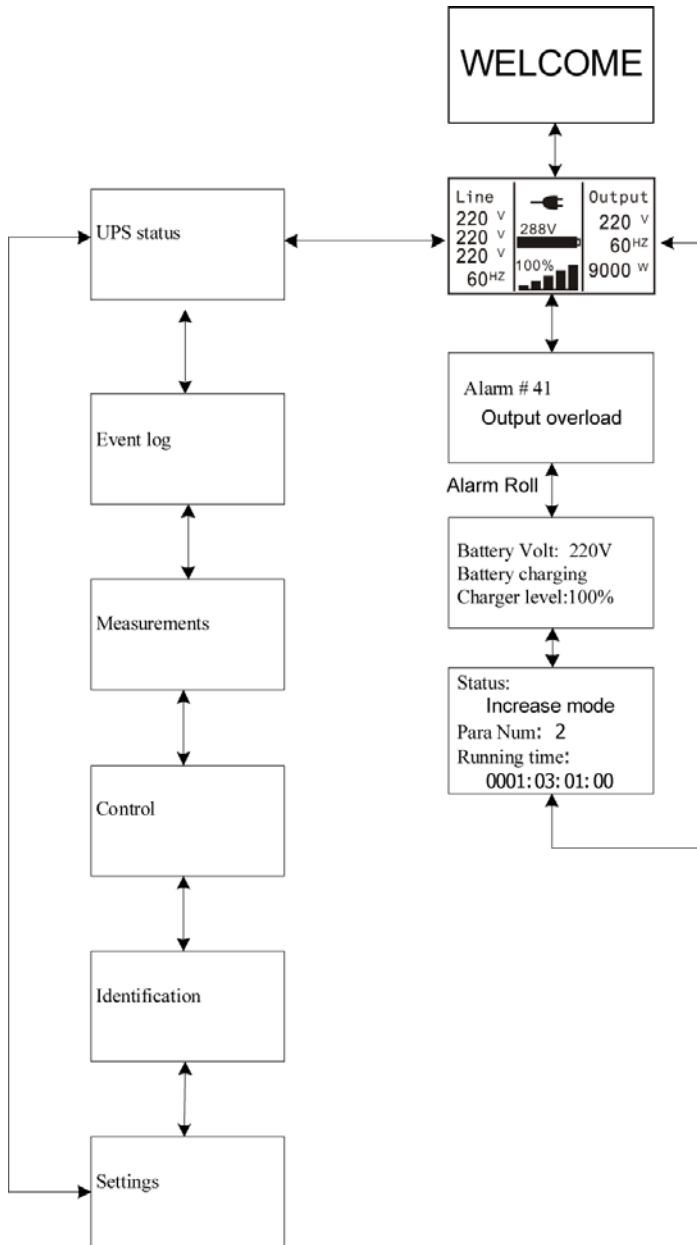



Fig. 5-14 Main menu tree

5.4.2 The UPS Status Menu

By pressing  on the menu of "UPS status", the display would enter the next UPS status menu tree.



The content of UPS status menu tree is same as the default UPS status summary menu.

By pressing  >1s, the display would return the last main menu tree.

The detail information about "UPS status", please see Fig5-14

5.4.3 The Event Log Menu

By pressing  on the menu of "Event log", the display would enter the next event menu tree.

All the old event, alarm and fault have been recorded here. The information includes the illustration, the event code, and the operating time of UPS when the event happened. By press  or  <1s, all the event could be displayed one by one.

The max number of record is 30, when the number is larger than 30, the oldest one would be changed to the newest information.

By pressing  >1s, the display would return the last main menu tree.

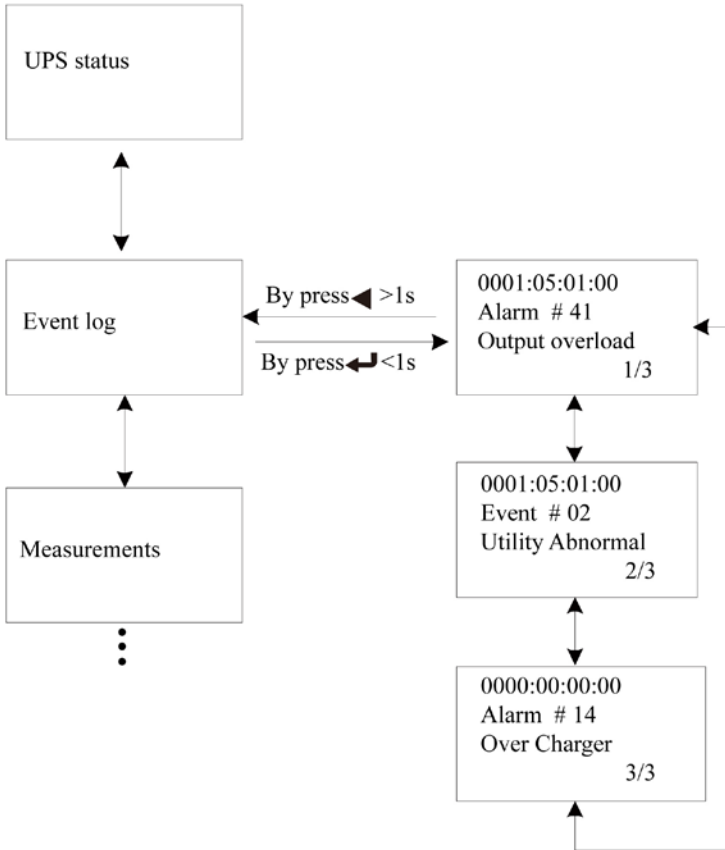

Fig. 5-15 Event menu tree

5.4.4 The Measurement Menu

By pressing **⏪** on the menu of "Measurement", the display would enter the next measurement menu tree.

A lot of detailed useful information could be checked here, Ex. the output voltage and frequency, the output current, the load capacity, the input voltage and frequency, etc.

By pressing **◀ >1s**, the display would return the last main menu tree.

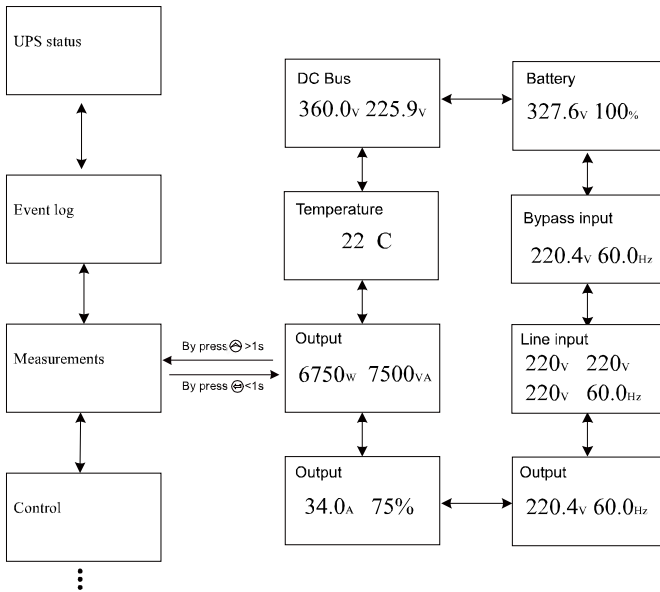

Fig. 5-16 Measurement menu tree

5.4.5 The Control Menu

By pressing  on the menu of "Control", the display would enter the next control menu tree.

- 1) Start Battery Test: is one command to control the UPS to do the battery test.
- 2) Clear EPO status: once EPO status is enabled, the UPS output would be cut off. To recover to normal status, first EPO connector should be **opened**, and enter this menu to clear EPO status, then UPS would stop alarm and recover to Bypass model. And UPS needs be turned on by manual operation.
- 3) Reset Fault status: when fault occurs, UPS would keep in Fault mode and alarm. To recover to normal status, enter this menu to reset error status, then UPS would stop alarm and recover to Bypass mode. And the reason of fault should be checked and deleted before UPS is turned on again by manual operation.

- 4) Restore factory settings: all the settings would be recover to default factory settings. It could only be done in Bypass mode.

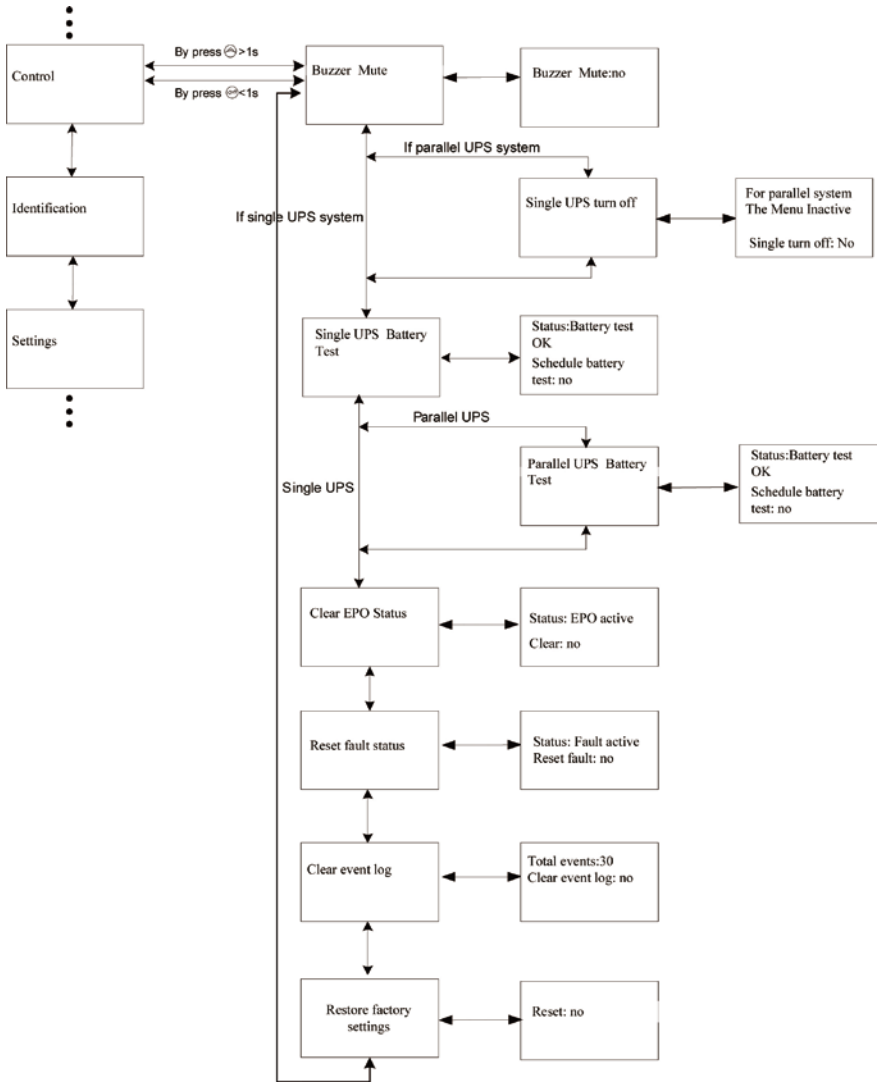

Fig. 5-17 Control menu tree

5.4.6 The Identification Menu

By press on the menu of "Identification", the display would enter the next identification menu tree.

The identification information includes UPS serial number, firmware serial number, model type, would be shown here.

By press >1s, the display would return the last main menu tree.

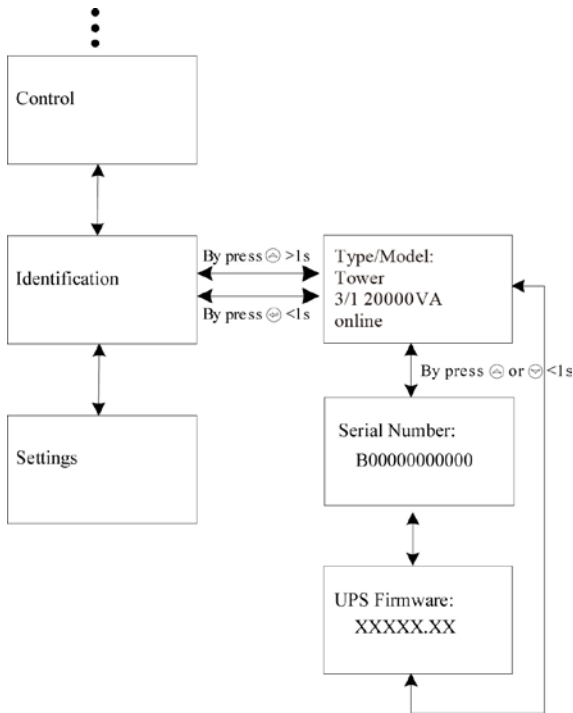

Fig. 5-18 Identification menu tree

5.4.7 The Setting Menu

Please contact your local distributor for further information before using the settings. Some settings would change the specification, and some settings would enable or disable some functions. The unsuitable option set by user may result in potential failures or protecting

function loss, even directly damage the load, battery or UPS.

The most of settings could only be done while UPS is in Bypass mode.

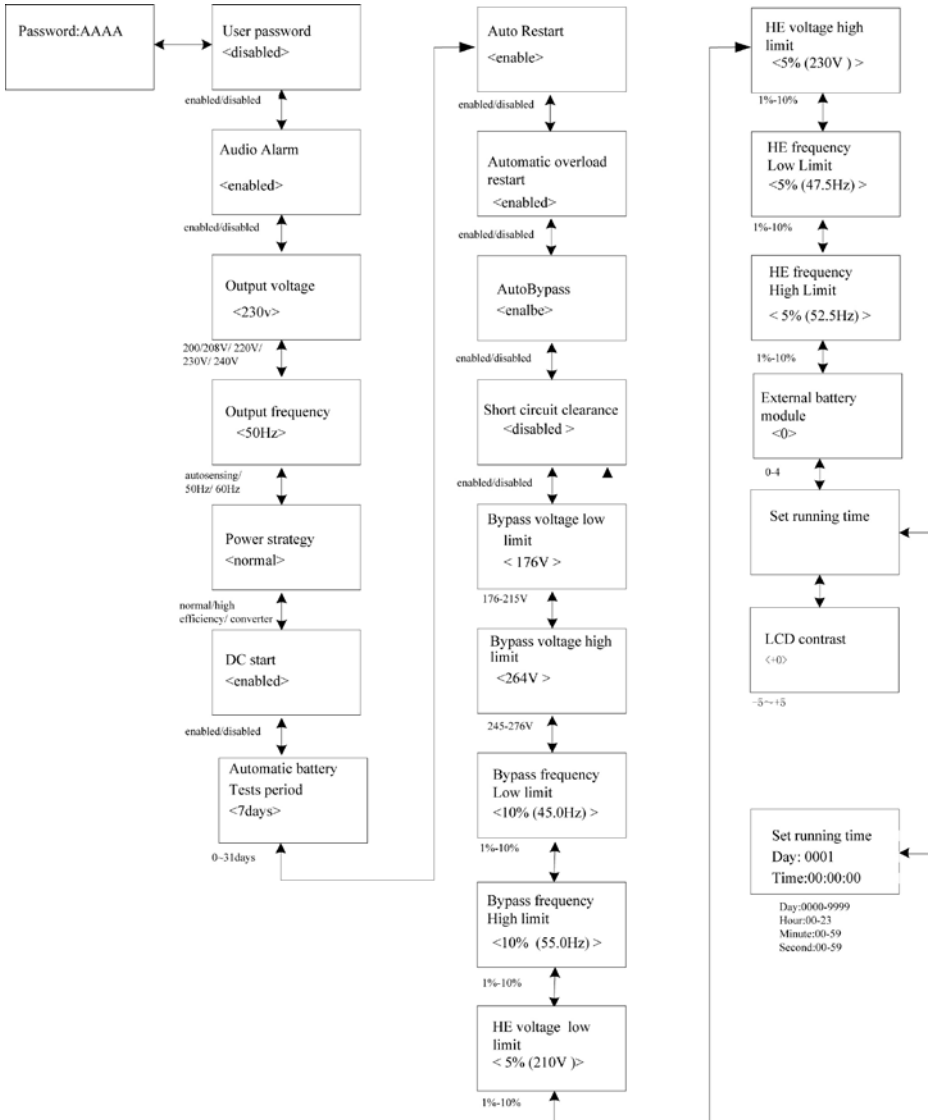

Fig. 5-19 Setting menu tree

***:Password is USER when enabled**

Example: set rated output voltage value

Setting menu tree

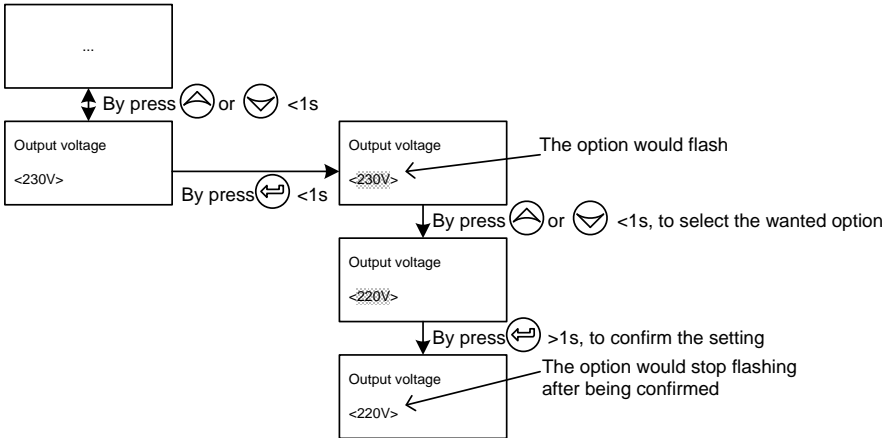

Fig. 5-20 Set rated output voltage value

6. Special Function

The series UPS has some special functions, which could satisfy some special application of user. And the functions have own features, please contact your local distributor for further information before using the function.

6.1 HE Function

6.1.1 Brief Introduction of HE Function

If HE function is set to enable, after the UPS is turned on, the power used by the load is directly supplied from the utility power via internal filter while the utility power is in normal range, so the high efficiency could be gained in HE mode. It is also called economy mode. Once the mains is loss or abnormal, the UPS would transfer to Line mode or Battery mode and the load is supplied continuously.

The great virtue is overall high efficiency >0.97 of UPS, to save power for user.

But the disadvantage is 1) the load can not be protected as well as in Line mode, for the load is directly supplied from the utility; 2) the transfer time of UPS output from HE mode to Battery mode is about 10ms.

So the function is not suitable to some sensitive loads, and the region where the utility power is unstable.

6.2 Converter Function

6.2.1 Brief introduction of Converter function

In converter mode, the UPS would free run with fixed output frequency (50Hz or 60Hz). Once the mains is loss or abnormal, the UPS would transfer to Battery mode and the load is supplied continuously.

The great virtue is the output frequency is fixed, which is required by some very sensitive loads.

But the load should be derated to 60% when running in converter mode with single phase input, and there is no derating with three phases input.

6.3 Parallel Function

6.3.1 Brief introduction of the redundancy

$N+X$ is currently the most reliable power supply structure. N represents the minimum UPS number that the total load needs, X represents the redundant UPS number, i.e. the fault UPS number that the system can handle simultaneously. When the X is larger, the reliability of the power system is higher. For occasions where reliability is highly depended on, $N+X$ is the optimal mode.

As long as the UPS is equipped with parallel cables, up to 4 UPSs can be connected in parallel to realize output power sharing and power redundancy.

6.3.2 Parallel installation and operation

How to install a new parallel UPS system:

- 1) Before installing a new parallel UPS system, user need to prepare the input and output wires, the output breaker, and the parallel cable.
- 2) Users need to use a standard 25-pin communication cable, which should have 25 cores, corresponding stitches and shield, as the UPS parallel cable. The length of the parallel cable is appropriate to be less than 3m. And there is one standard parallel cable in the accessories of every UPS.
- 3) Remove the cover plate of the parallel port on the UPS, connect each UPS one by one with the parallel cable, and re-screw the Parallel port cover which is supplied in the accessories.

- 4) Strictly follow the chapter of 4, the wiring requirement of single UPS to perform the wiring of each UPS.
- 5) Connect the output wires of each UPS to an output breaker panel.
- 6) Disconnect the Jumper on JP1 and JP2 of the terminal block first, and connect each output breaker to a main output breaker and then to the loads.
- 7) Each UPS need an independent battery pack.
- 8) Please refer to the wiring diagram in the following diagram.
- 9) The distance between the UPSs in parallel and the breaker panel is required to be less than 20 meters. The difference between the wires of input and output of the UPSs is required to be less than 20%.

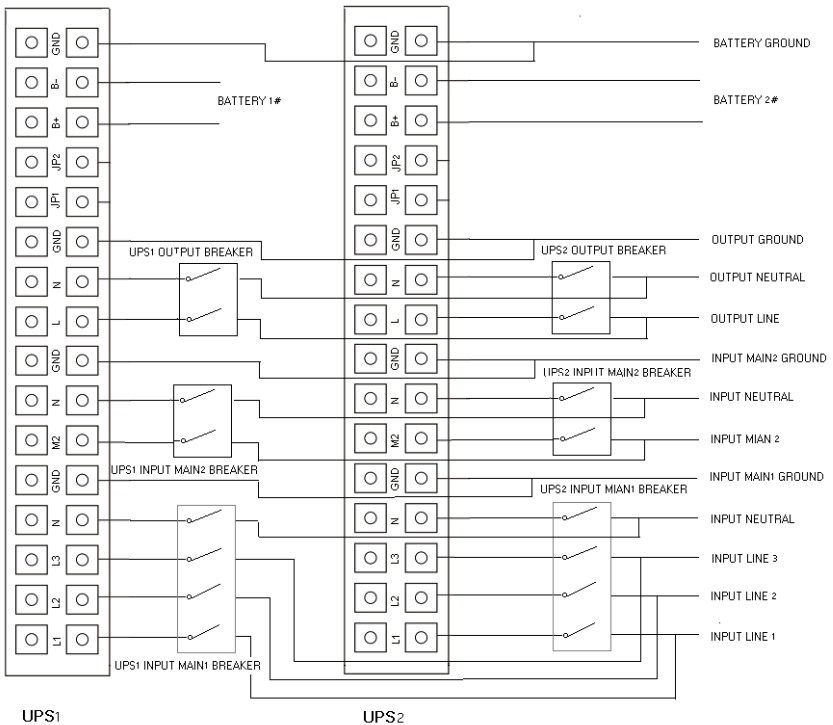

Fig. 6-1 Input and output Terminal Block wiring diagram of PowerWalker VFI 10000-20000TP 3/1

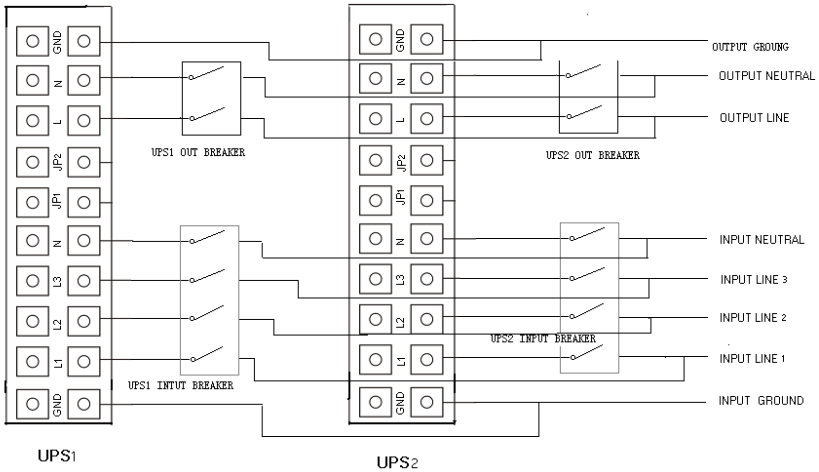

Fig. 6-2 Input and output Terminal Block wiring diagram of PowerWalker VFI 10000-20000 TP 3/1 model

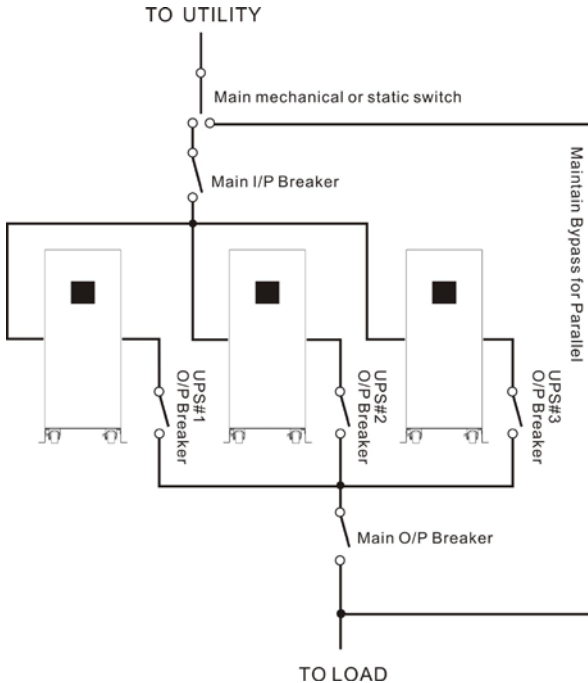







Fig. 6-3 Parallel Installation Diagram

- 10) Do not switch on the output breaker of each UPS, switch on the input breaker of the each UPS, the UPS should work in bypass with output, observe their display to check if there are any warning or fault information, measure the output voltage of each UPS separately to check if the voltage difference between them is less than 1V. If the difference is more than 1V, check the wiring.
- 11) Press the  button of one UPS, each UPS would start to turn on, all the UPSs would transfer to the INV mode together. Measure the output voltage of each UPS separately to check if the voltage difference between them is less than 0.5V. If the difference is more than 1V, the UPSs need to be regulated.
- 12) Press the  button of one UPS, each UPS would start to turn off and transfer to the Bypass mode, switch on the output breaker of each UPS to parallel all the output of UPSs together.
- 13) Press the  button of one UPS, each UPS would start to turn on, after turning on, the UPSs should work parallel in the Line mode.

How to join a new UPS to a parallel system:

- 1) First the parallel system must be installed one main maintenance mechanical switch or static switch.
- 2) Regulate the output voltage of the new UPS separately: check if the output voltage difference between the new UPS and the parallel system is less than 0.5V.
- 3) Ensure the bypass of the parallel system is normal and the bypass setting is "enable", remove the cover plate of maintenance switch on the rear panel of each UPS, the UPS system would transfer to bypass automatically, For PowerWalker VFI 10000-20000TP 3/1, set the own maintenance switch of each UPS from "UPS" to "BPS". For PowerWalker VFI 10000TCP 3/1 model, turn the maintenance switch in the "ON" position, and turn the output switch in the "OFF" position.

- 4) For PowerWalker VFI 10000-20000TP 3/1, Set the main maintenance switch or static switch from "UPS" to "BPS", For PowerWalker VFI 10000TCP 3/1 model, turn the maintenance switch in the "ON" position, and turn the output switch in the "OFF" position, switch off the main output breaker and the main input breaker, the UPSs would shut down.
- 5) Ensure the UPSs shut down totally, add the new UPS and reinstall the new UPS parallel system by following step 1) to 9) of last chapter - "install a new parallel UPS system".
- 6) For PowerWalker VFI 10000-20000TP 3/1, Switch on the main input breaker and the main output breaker, and set the main maintenance switch or static switch from "BPS" to "UPS", then set the UPS own maintenance switch from "BPS" to "UPS" and screw the maintenance cover plate back again. Press the  button of one UPS, each UPS would start to turn on, after turning on, the UPSs should work parallel in the Line mode.

For PowerWalker VFI 10000TCP 3/1 model, turn the maintenance switch in the "OFF" position, and turn the output switch in the "ON" position, then turn the UPS own maintenance switch in the "OFF" position, and turn the UPS own output switch in the "ON" position, then screw the maintenance cover plate back again. Press the  button of one UPS, each UPS would start to turn on, after turning on, the UPSs should work parallel in the Line mode.

How to remove a single UPS from a parallel system:

- 1) First the parallel system must be installed one main maintenance mechanical switch or static switch.
- 2) Ensure the bypass is normal and the bypass setting is "enable", remove the cover plate of maintenance switch on the rear panel of each UPS, the UPS system would transfer to bypass automatically, For PowerWalker VFI 10000-20000TP 3/1, set the own

maintenance switch of each UPS from "UPS" to "BPS". For PowerWalker VFI 10000TCP 3/1 model, turn the own maintenance switch in the "ON" position, and turn the own output switch in the "OFF" position.

- 3) For PowerWalker VFI 10000-20000TP 3/1, Set the main maintenance switch or static switch from "UPS" to "BPS", switch off the main output breaker and the main input breaker, and the UPSs would shut down.

For PowerWalker VFI 10000TCP 3/1 model, turn the own maintenance switch in the "ON" position, switch off the main output switch and the main input switch, and the UPSs would shut down.

- 4) Ensure the UPSs shut down totally, remove the wanted UPS and reinstall the new UPS parallel system by following step 1) to 9) of last chapter - "install a new parallel UPS system".
- 5) If the removed UPS or the remained UPS will be used in a stand-alone mode, then JP1 and JP2 on the terminal block should be connected with a short connection wire.
- 6) Switch on the main input breaker/switch and the main output breaker/switch, For PowerWalker VFI 10000-20000TP 3/1 ,set the main maintenance switch or static switch from "BPS" to "UPS", then set the UPS own maintenance switch from "BPS" to "UPS" and screw the maintenance cover plate back again. For PowerWalker VFI 10000TCP 3/1 model, turn the maintenance switch in the "OFF" position, then turn the own maintenance switch in the "OFF" position and screw the maintenance cover plate back again, then Press the  button of one UPS, each UPS would start to turn on, after turning on, the UPSs should work parallel in the Line mode.

6.4 PowerWalker VFI 10000TP 3/1 Optional Design of Charger Current

6.4.1 Our charger output current has two optional levels (2A&4A) for different battery pile.

6.4.2 Operate method:

2A charger current method

Insert short circuit pin 104-10000-01 in the CN7 position of charger board. This is charging for 7AH*24 pcs or 9AH*24 pcs.

4A charger current method

Pull out short circuit pin 104-10000-01 from CN7 position of charger board. This is for 2 piles of 7AH*24 pcs or 2 piles of 9AH*24 pcs.

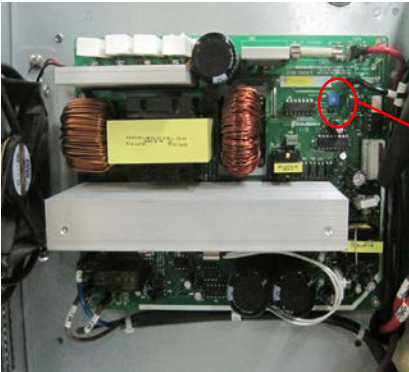

Short circuit pin 104-10000-01



6.5 Backfeed Protection

To support protection against UPS backfeeding a new logic is integrated into PowerWalker VFI 10000-20000TP 3/1 model. But in PowerWalker VFI 10000TCP 3/1 model , there's no this function.

Using backfeed protection

On customers side an additional external isolation device (magnetic contactor, MC or minimum voltage tripping device) must be provided as shown in Fig. 6-3. The isolation device must be able to carry the UPS input current (see resp. table of basic UPS operating instructions).

The isolation device has to be installed in the bypass source path. Cabling of the backfeed terminals contains a jumper and two cables to the optional external isolation device.

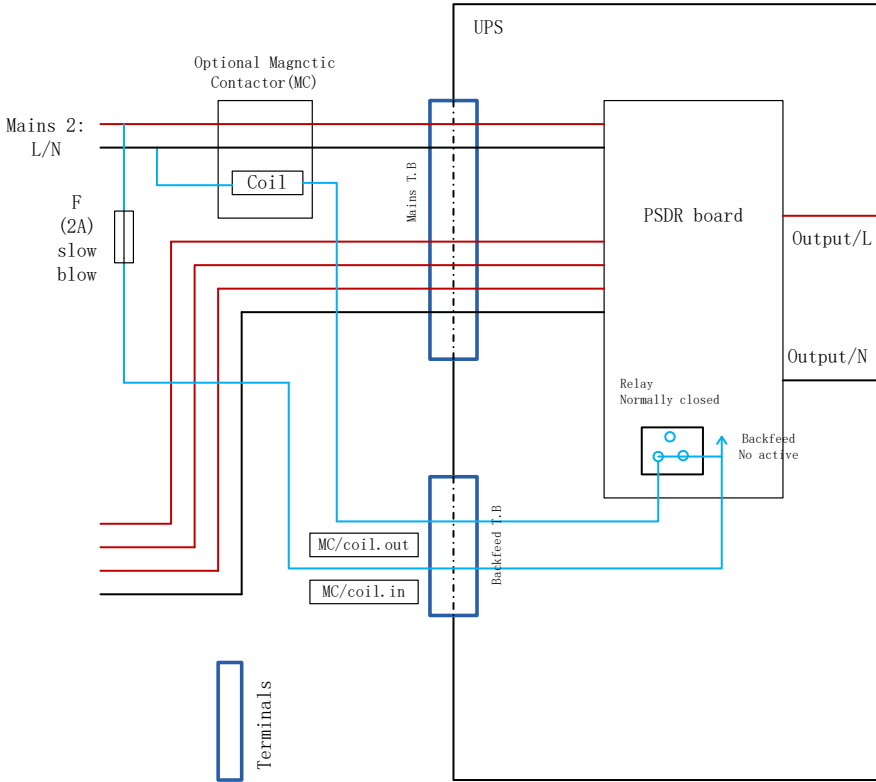

Fig. 6-4 PowerWalker VFI 10000-20000 TP 3/1 and external isolation device(in this example a magnetic contactor (MC))

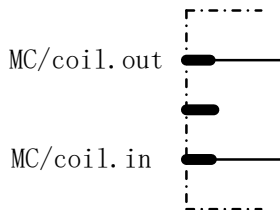

Fig. 6-5 Backfeed terminal

Operation

If bypass thyristor is short (short circuit) and UPS runs in double conversion mode (online) the following steps follow:

The backfeed relay opens and the message "backfeeder" is shown on the LCD panel

Reset

To reset the backfeed logic the UPS device must be switched Off for some seconds

7. Trouble Shooting

If the UPS system does not operate correctly, first check the operating information on the LCD display.

Please attempt to solve the problem using the table below. If the problem still persists, consult your dealer.

7.1 Trouble Shooting According To Warning Indication

Problem Displayed	Possible cause	Remedy
Epo Active Alarm code:71	EPO connector is closed	Check the EPO connector status
On Maintain Bypass Alarm code:72	Maintain bypass switch is open	Check the maintain bypass switch status
Battery Disconnect Alarm code:11	Battery pack is not connected correctly	Do the battery test to confirm. Check the battery bank is connected to the UPS. Check the battery breaker is turn on.
Battery low Alarm code:12	Battery voltage is low	When audible alarm sounding every second, battery is almost empty.
Output Overload Alarm code:41	Overload	Check the loads and remove some non-critical loads. Check if some loads are failed.
Fan Failure Alarm code:84	Fan abnormal	Check if the fan is running normally.
Charger Fail Alarm code:15	The charge fails	Consult dealer.
Over Charge Alarm code:14	Battery is over charged	The UPS will turn off the charger until the battery voltage is normal
Model Pin Error Alarm code:92	UPS internal fault	Consult dealer.

Heatsink Over Temperature Alarm code:86	Inside temperature of UPS is too high	Check the ventilation of UPS and the ambient temperature.
Para Cable Male Loss Alarm code:E3	The parallel cable is disconnected	Check the parallel cable.
Para Cable Female Loss Alarm code:E4	The parallel cable is disconnected	Check the parallel cable.
Para Bat Differ Alarm code:E6	The battery packs of some UPSs are disconnected	Check if all the battery pack is connected.
Para Byp Differ Alarm code:E8 (PowerWalker VFI 10000TCP 3/1 mode has no this case)	The M2 bypass input of some UPSs is disconnected	Check the building wiring and input cable. Check if the M2 breaker is closed. Ensure the UPSs are connected to same input source.
Para Line Differ Alarm code:E7	The M1 line input of some UPSs is disconnected	Check the building wiring and input cable. Check if the M1 breaker is closed. Ensure the UPSs are connected to same input source.
Para Work Mode Differ Alarm code:E9	There are different power strategy setting in parallel system	The UPSs with different power strategy setting (Ex. one Line mode and one Converter mode) are forbidden to parallel.
Para Rate Power Differ Alarm code:EA	There are different UPSs in parallel system	The UPSs with different capacity (Ex. one 10KVA and one 20KVA) are forbidden to parallel.
ECO In Para Alarm code:EB	HE function is enabled in parallel system	HE function is forbidden in parallel system.

7.2 Trouble Shooting According To Fault Indication

Problem Displayed	Possible cause	Remedy
Inv Overload Fault Alarm code:42	Overload	Check the loads and remove some non-critical loads. Check if some loads are failed.
Byp Overload Fault Alarm code:43	Overload	Check the loads and remove some non-critical loads. Check if some loads are failed.
Output Short Circuit Alarm code:31	Output short circuit	Remove all the loads. Turn off the UPS. Check if UPS output and loads is short circuit. Ensure short circuit is removed before turning on again.
Heatsink Over Temperature Fault Alarm code:81	Inside temperature of UPS is too high	Make sure the UPS is not overloaded; the air vents are not blocked and the ambient temperature is not too high. Wait for 10 minutes for the UPS to cool down before turning on again. If failed, please contact the distributor or service center.
Bus Over Voltage Alarm code:21	UPS internal fault	Consult dealer.
Bus Under Voltage Alarm code:22	UPS internal fault	Consult dealer.
Bus Unbalance Alarm code:23	UPS internal fault	Consult dealer.
Bus short Alarm code:24	UPS internal fault	Consult dealer.
Bus Softstart Fail Alarm code:25	UPS internal fault	Consult dealer.
Inv Over Voltage Alarm code:32	UPS internal fault	Consult dealer.

Inv Under Voltage Alarm code:33	UPS internal fault	Consult dealer.
Inv Softstart Fail Alarm code:34	UPS internal fault	Consult dealer.
Negative Power Fault Alarm code:E1	The load is pure inductive and capacitive	Remove some non-critical loads. Bypass supplies the load first, ensure there is no overload, then turn on UPS.
Cable male and female Loss fault Alarm code:E2	The parallel cable is disconnected	Check the parallel cable.
Backfeeder Alarm code:93	UPS internal fault	Don't touch any terminal of the equipments which connect one utility power with the UPS even you cut off the utility power. Please Consult dealer.

7.3 Trouble Shooting In Else Cases

Problem	Possible cause	Remedy
No indication, no warning tone even though system is connected to mains power supply	No input voltage	Check the building wiring and input cable. Check if the input breaker is closed.
BYPASS LED light up even though the power supply is available	Inverter not switched on	Press On-Switch "I" to turn on UPS.
BATTERY LED lights up, and audible alarm sounding every 1 beep in every 4 seconds	Input voltage and/or frequency are out of tolerance	Check input power source. Check the building wiring and input cable. Check if the input breaker is closed.

Emergency supply period shorter than nominal value	Batteries not fully charged / batteries defect	Charge the batteries for at least 12 hours and then check capacity.
--	--	---

Please have the following information at hand before calling the After-Sales Service Department:

1. Model number, serial number
2. Date on which the problem occurred
3. LCD/LED display information, Buzzer alarm status
4. Utility power condition, load type and capacity, environment temperature, ventilation condition
5. The information (battery capacity, quantity) of external battery pack if the UPS is "S" model
6. Other information for complete description of the problem

8. Battery Maintenance, Replacement and Disposal

8.1 Maintenance

- This series UPS only requires minimal maintenance. The battery used for standard models are value regulated sealed lead-acid maintenance free battery. These models require minimal repairs. The only requirement is to charge the UPS regularly in order to maximize the expected life of the battery. When being connected to the utility power, whether the UPS is turned on or not, the UPS keeps charging the batteries and also offers the protective function of overcharging and over-discharging.
- The UPS should be charged once every 4 to 6 months if it has not been used for a long time.
- In the regions of hot climates, the battery should be charged and discharged every 2 months. The standard charging time should be at least 12 hours.
- Under normal conditions, the battery life lasts 3 to 5 years. In case if the battery is found not in good condition, earlier replacement should be made. Battery replacement should be performed by qualified personnel.
- Replace batteries with the same number and same type of batteries.
- Do not replace the battery individually. All the batteries should be replaced at the same time following the instructions of the battery supplier.
- Normally, the batteries should be charged and discharged once every 4 to 6 months. Charging should begin after the UPS shuts down automatically in the course of discharging, the standard charging time for the standard UPS should be at least 12 hours.

8.2 Replacement and Disposal of Batteries

- 1) Before disposing of batteries, remove conductive jewelry such as necklace, wrist watches and rings.
- 2) If it is necessary to replace any connection cables, please purchase the original materials from the authorized distributors or service centers, so as to avoid overheat or spark resulting in fire due to insufficient capacity.
- 3) Do not dispose of batteries or battery packs in a fire, they may explode.
- 4) Do not open or mutilate batteries, released electrolyte is highly poisonous and harmful to the skin and eyes.
- 5) Do not short the positive and negative of the battery electrode, otherwise, it may result in electric shock or fire.
- 6) Make sure that there is no voltage before touching the batteries. The battery circuit is not isolated from the input potential circuit. There may be hazardous voltage between the battery terminals and the ground.
- 7) Even though the input breaker is disconnected, the components inside the UPS are still connected with the batteries, and there are potential hazardous voltages. Therefore, before any maintenance and repairs work is carried out, switch off the breaker of the battery pack or disconnect the jumper wire of connecting between the batteries.
- 8) Batteries contain hazardous voltage and current. Battery maintenance such as the battery replacement must be carried out by qualified personnel who are knowledgeable about batteries. No other persons should handle the batteries.

Easy for Battery Replacement (for PowerWalker VFI 10000-20000 TP 3/1model)

Open the front panel and request service engineer to replace batteries. Steps:

- 1) Remove the front panel and disconnect the connector on the LCD display board. See Fig. 8-1.

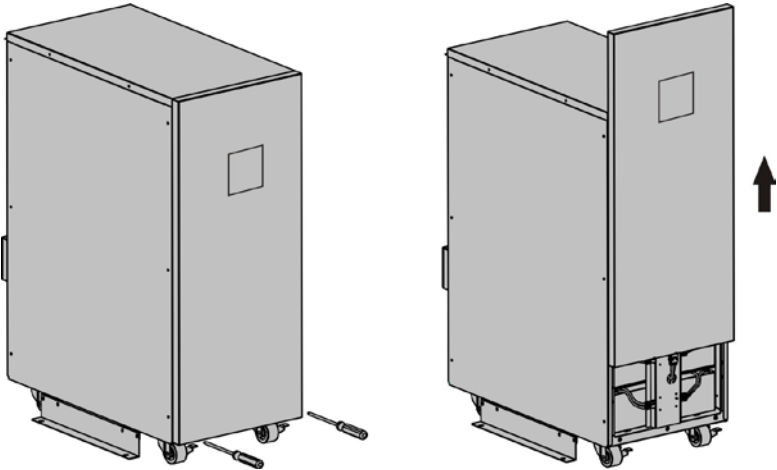

Fig. 8-1 Easy for Battery Replacement -Step 1

- 2) Disconnect the battery pack DC connectors and remove the battery fixed plate. See Fig. 8-2.

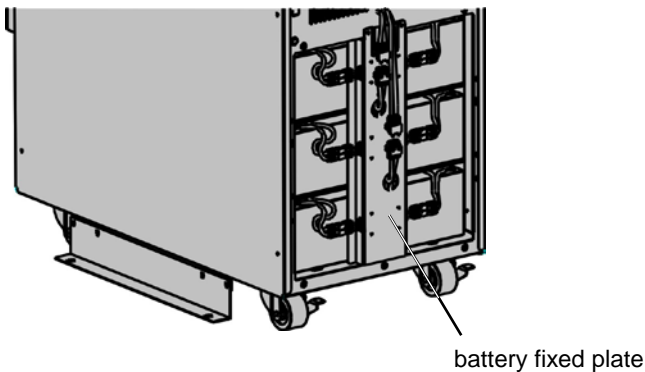

Fig. 8-2 Easy for Battery Replacement -Step 2

- 3) Remove the battery pack from the cabinet. See Fig. 8-3.

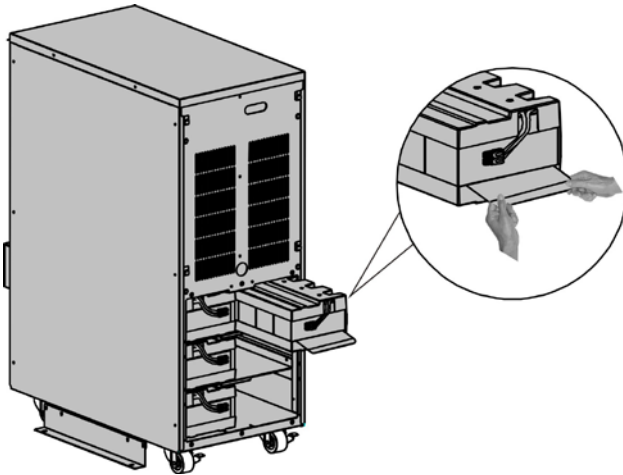

Fig. 8-3 Easy for Battery Replacement -Step 3

- 4) Replace the old battery packs with the new ones.
- 5) Reconnect the DC cables.

Note: The battery pack is 20kg weight, be careful not to fall off when you operate the battery replacement.

If you want to replace batteries without powering down the UPS, you need to set the UPS work in Bypass Mode. That is to remove the maintenance switch cover plate of UPS and set the maintenance switch from “UPS” to “BPS”, turn the M1/M2/N input breaker in the “OFF” position(you need open the N breaker’s cover at first), and then you can replace it.

9. Communication Port

9.1 RS232&USB Interface

RS232&USB interface is for the monitoring software and firmware update. There is only one option can work in the same time and same product.

- 1) The following is the pin assignment and description of DB-9 connector.

Pin #	Description	I/O
2	TXD	Output
3	RXD	Input
5	GND	Input

- 2) The USB port is compliance with USB 1.1 protocol for its communication software.

9.2 Intelligent Slot

This series is equipped with two intelligent slot for Webpower (optional accessory) or other optional card to achieve remote management of the UPS through internet / intranet. Please contact your local distributor for further information.

9.3 AS400 Interface (Option)

Except for the communication protocol as mentioned above, this series UPS has AS400 card (an optional accessory) for AS400 communication protocol. Please contact your local distributor for details. The following is the pin assignment and description of DB-9 connector in AS400 card.

Pin #	Description	I/O	Pin #	Description	I/O
1	UPS Fail	Output	6	Bypass	Output
2	Summary Alarm	Output	7	Battery Low	Output
3	GND	Input	8	UPS ON	Output
4	Remote Shutdown	Input	9	Line Loss	Output
5	Common	Input			

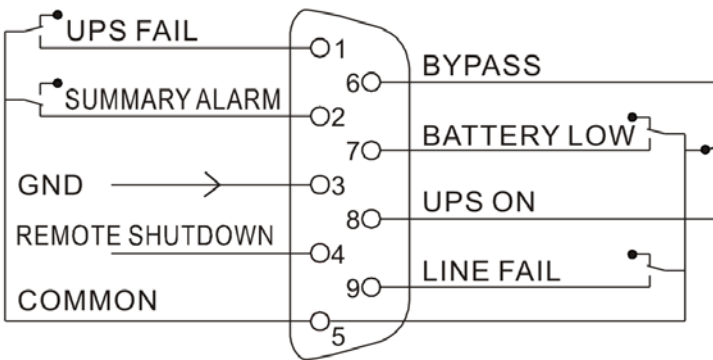

Fig. 9-1 signal of AS400 interface

10. Software Installation

WinPower is UPS monitoring software, featuring user-friendly interface to monitor and control your UPS. This unique software provides complete power protection for computer system while power failure. With the software users can monitor any UPS status on the same LAN. Furthermore, a UPS can provide security protection for more than one computer on the same LAN at the same time, such as shutting down system in security, saving application data and shutting down the UPS when power fails.

Software Installation on your PC:

Connected by USB to a PC or notebook, the Software enables communication between the UPS and the computer. The UPS software monitors the status of the UPS, shuts down the system before the UPS is exhausted and can remotely observe the UPS via the Network (enabling users to manage their system more effectively). Upon AC failure or UPS battery low, UPS takes all necessary actions without intervention from the system administrator. In addition to automatic file saving and system shut-down functions, it can also send warning messages via pager, e-mail etc.

- Use the bundled CD and follow the on-screen instructions to install the software WinPower.
- Enter the following serial No. to install software: 511C1-01220-0100-478DF2A
- After the software is successfully installed, the communication with UPS has been established and an green icon will appear in the system tray.



- Double-click the icon to use the monitor software (as above).

- You can schedule UPS shutdown/start-up and monitor UPS status through PC.
- Detail instructions please refer to the e-manual in the software.



Check www.powerwalker.com/winpower.html from time to time to get the latest version of monitoring software.